

THIS DRAWING IS UNPUBLISHED. RELEASED FOR PUBLICATION
 © COPYRIGHT BY TYCO ELECTRONICS CORPORATION. ALL RIGHTS RESERVED.

LOC		DIST		REVISIONS			
P	LTR	DESCRIPTION	DATE	DWN	APVD		
FT	8	AC1	REVISED PER ECO-06-5544	3/14/06	SS	GS	

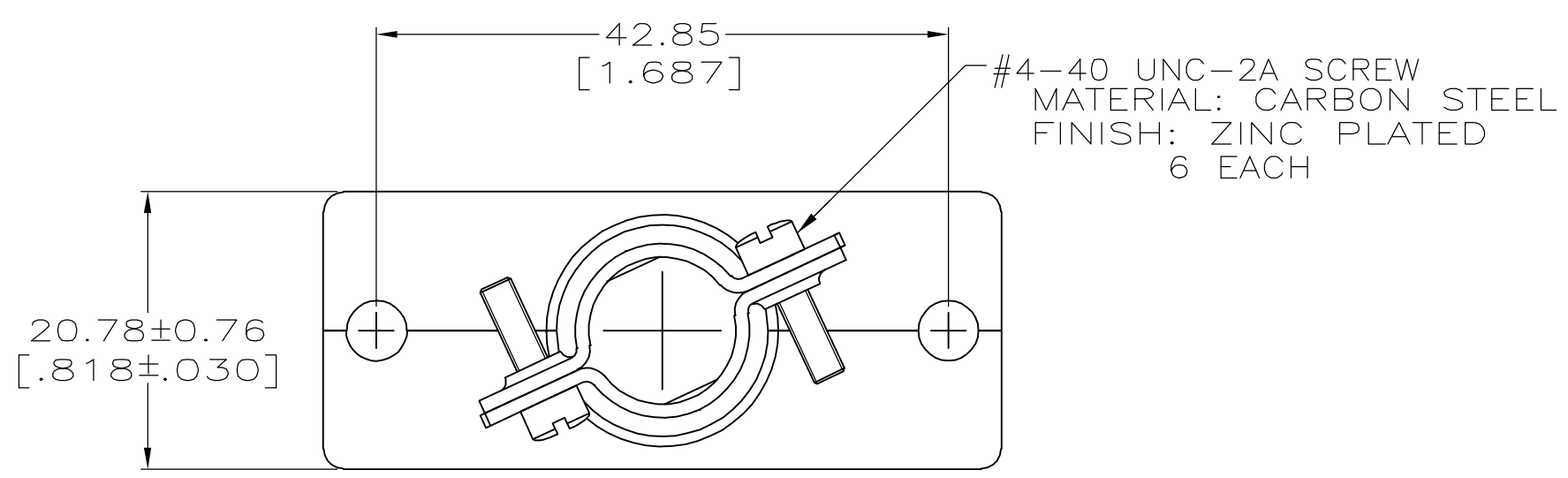

- ① AMP, PART NUMBER AND DATE CODE, INK STAMPED ON (1) OR BOTH SIDES.
- ② HEXAVALENT CHROMATE COATING.
- ③ NON-HEXAVALENT CHROMATE COATING.

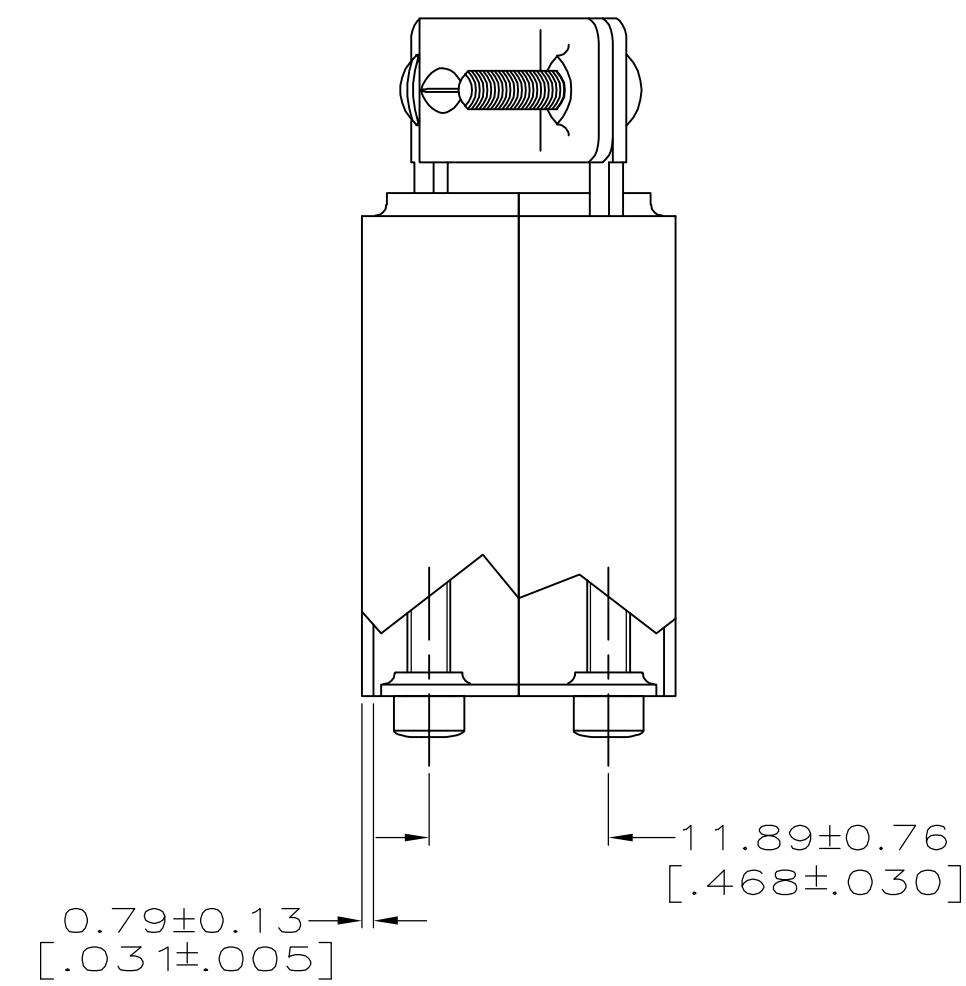
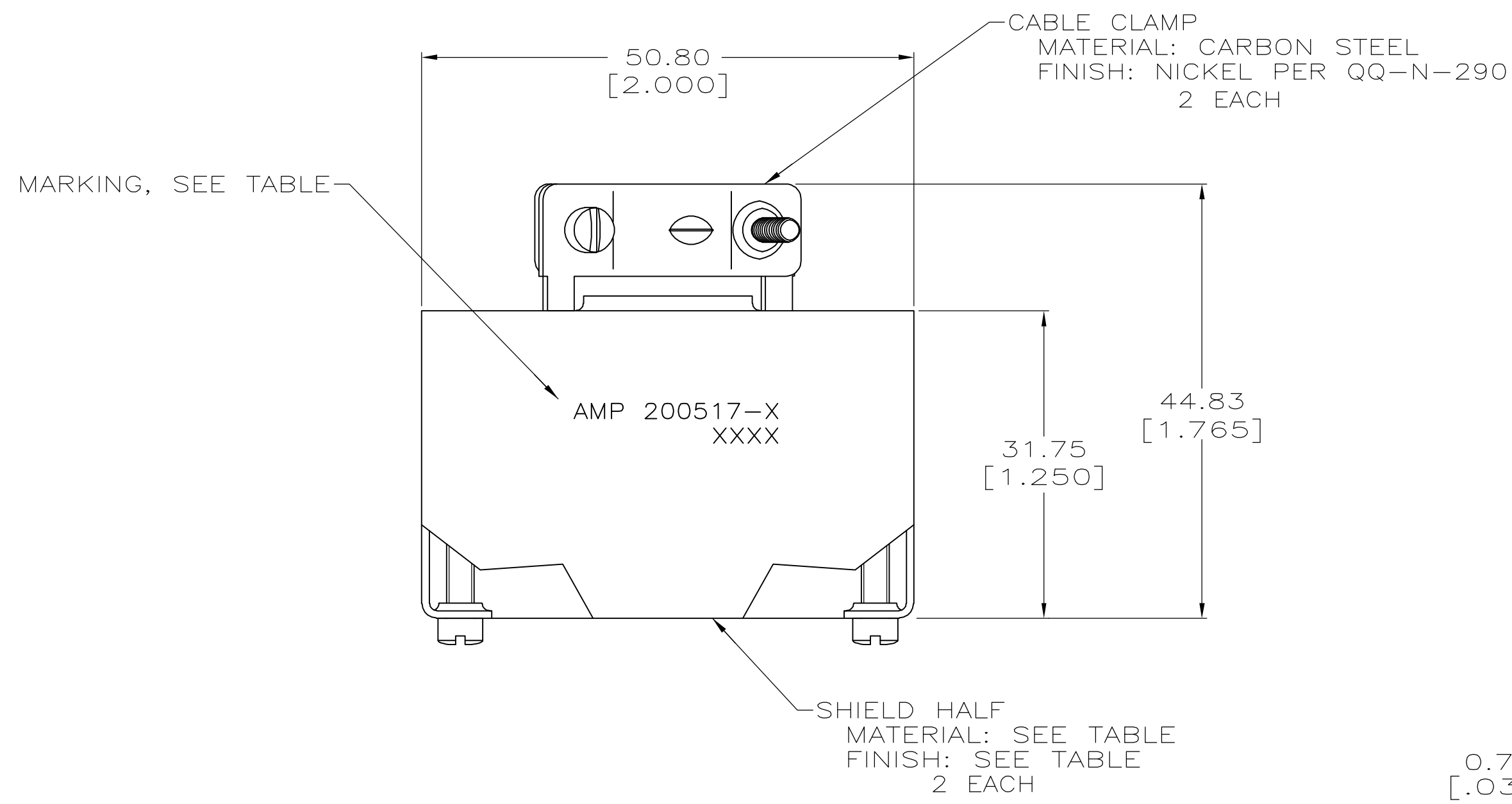

NOTES	CABLE RANGE DIA	MARKING	FINISH	MATERIAL	PART NUMBER
③	11.05-13.84 [.435-.545]	①	NICKEL PER QQ-N-290	CARBON STEEL	200517-9
②	7.62-11.43 [.300-.450]	①	NICKEL PER QQ-N-290	CARBON STEEL	200517-8
②	11.05-13.84 [.435-.545]	-	CLEAR ANODIZED	ALUMINUM ALLOY	200517-7
②	11.05-13.84 [.435-.545]	①	NICKEL PER QQ-N-290	CARBON STEEL	200517-2
②	11.05-13.84 [.435-.545]	①	CLEAR ANODIZED	ALUMINUM ALLOY	200517-1

THIS DRAWING IS A CONTROLLED DOCUMENT.

DWN	K.FOLTZ	01/23/95
CHK	R.STONE	01/24/95
APVD	-	-
PRODUCT SPEC	-	-
APPLICATION SPEC	-	-
WEIGHT	-	-
CUSTOMER DRAWING	SCALE	2:1

tyco Electronics
 Tyco Electronics Corporation
 Harrisburg, PA 17105-3608

NAME: SHIELD KIT, UNASSEMBLED, SHORT, 34 POSITION, M SERIES

SIZE	A2	CAGE CODE	00779	DRAWING NO	C=200517	RESTRICTED TO	-
SHEET	1	OF 1	REV	AC1			